

© COPYRIGHT OF THIS DRAWING IS RESERVED BY DBFL CONSULTING ENGINEERS. NO PART SHALL BE REPRODUCED OR TRANSMITTED WITHOUT THEIR WRITTEN PERMISSION.

NO CHANGES OF WHATSOEVER NATURE ARE TO BE MADE TO ANY DETAILS SET OUT OR CONTAINED IN ANY DBFL SPECIFICATIONS OR DRAWINGS UNLESS THE EXPRESS CONSENT HAS BEEN OBTAINED IN ADVANCE, IN WRITING, FROM DBFL.

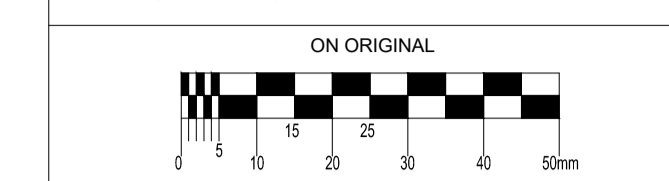

- NOTES:
- C20/25 CONCRETE TO HAVE A MINIMUM CEMENT CONTENT OF 260kg/m³, MAXIMUM WATER/CEMENT RATIO OF 0.65 AND SLUMP CLASS S2.
 - C25/30 CONCRETE TO HAVE A MINIMUM CEMENT CONTENT OF 280kg/m³, MAXIMUM WATER/CEMENT RATIO OF 0.65 AND SLUMP CLASS S2.
 - C40/50 CONCRETE TO HAVE A MINIMUM CEMENT CONTENT OF 400kg/m³, MAXIMUM WATER/CEMENT RATIO OF 0.45 AND SLUMP CLASS S3.
 - WHERE CLASS 6F1/6F2 CAPPING MATERIAL IS PROPOSED WITHIN 500mm OF CONCRETE OR STEEL, CLASS 6N TO BE USED INSTEAD.
 - WHERE FOOTPATHS ARE LOCATED ADJACENT TO ROADS, C40/50 CONCRETE TO BE USED. ALTERNATIVELY, FOOTPATHS LOCATED BEHIND VERGES C25/30 CONCRETE MAY BE USED.

NOTE:
ALL WORKS & SPECIFICATIONS TO BE UNDERTAKEN IN ACCORDANCE WITH
• TII SPECIFICATION FOR ROADWORKS
• GREATER DUBLIN CODE OF PRACTICE FOR DRAINAGE WORKS
• RECOMMENDATIONS FOR SITE DEVELOPMENT WORKS

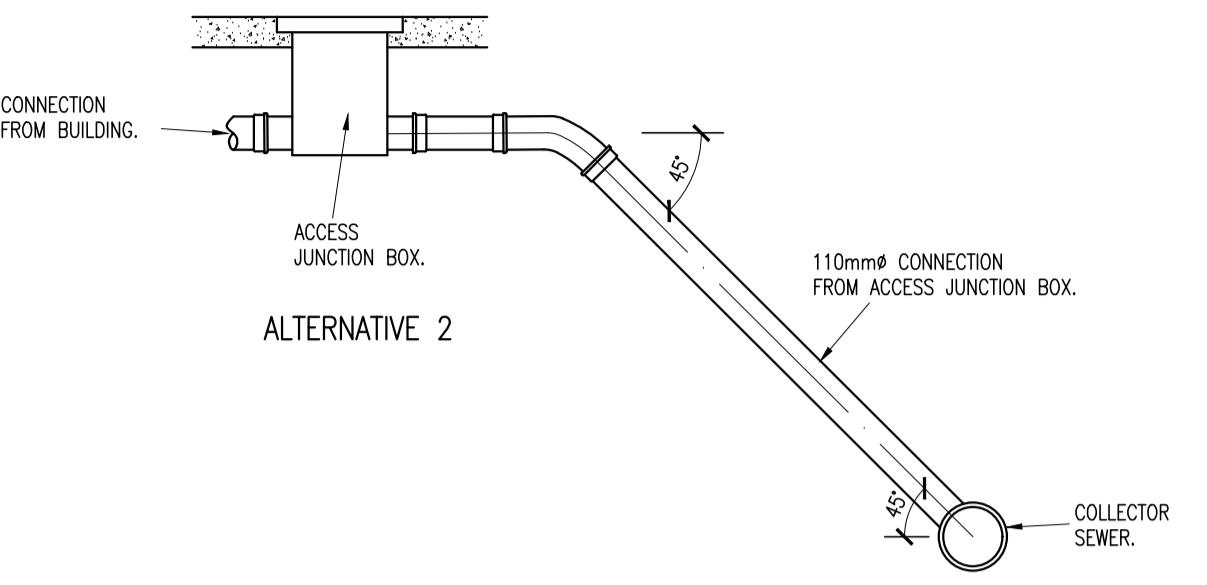
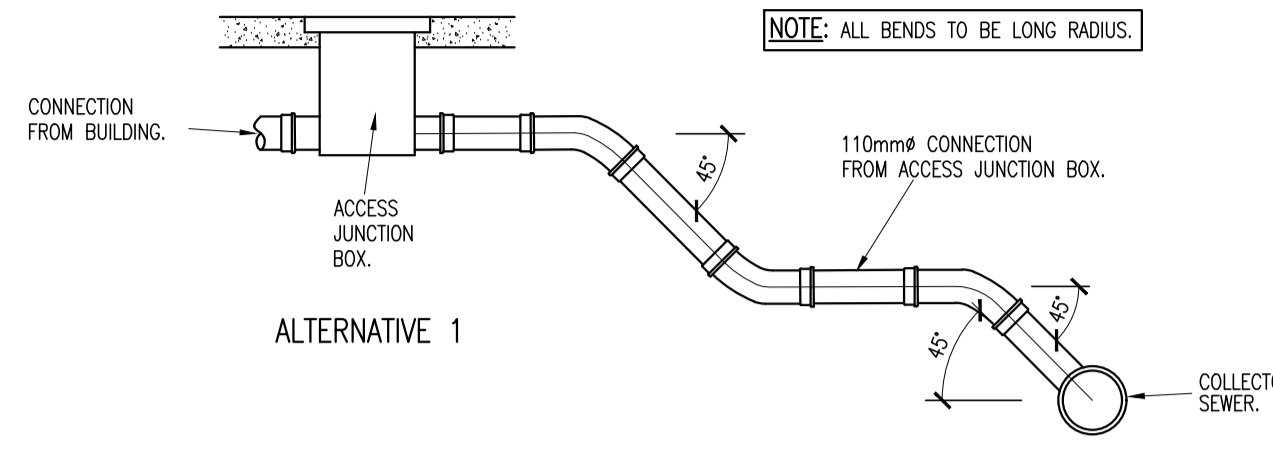
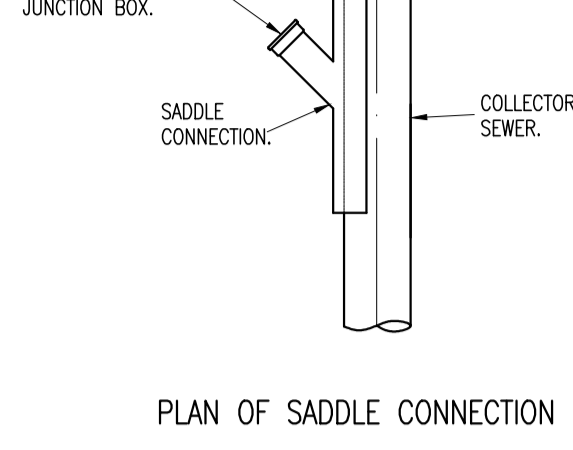
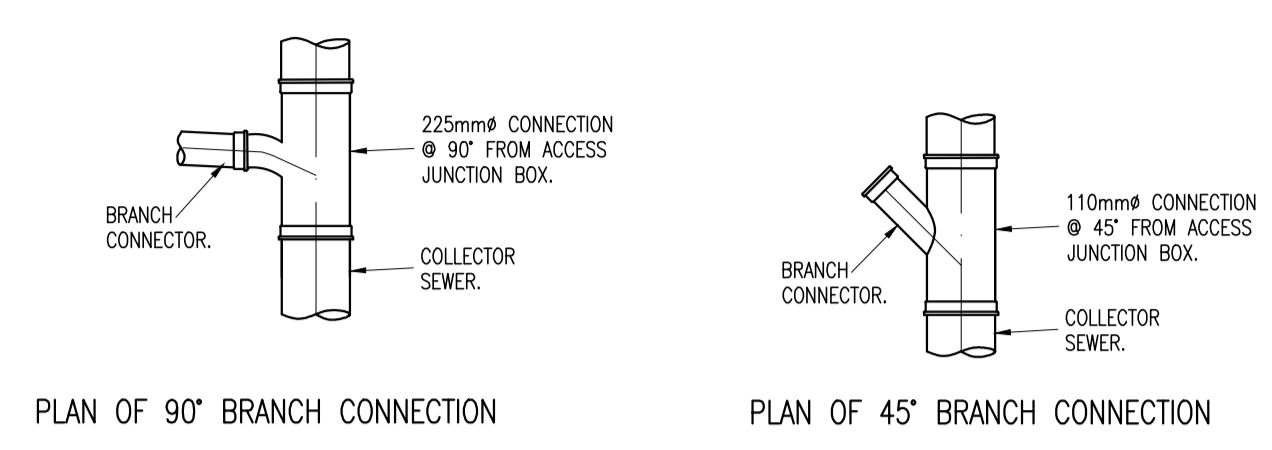

SADDLE CONNECTION FROM ACCESS JUNCTION (AJ) BOX TO COLLECTOR SEWER

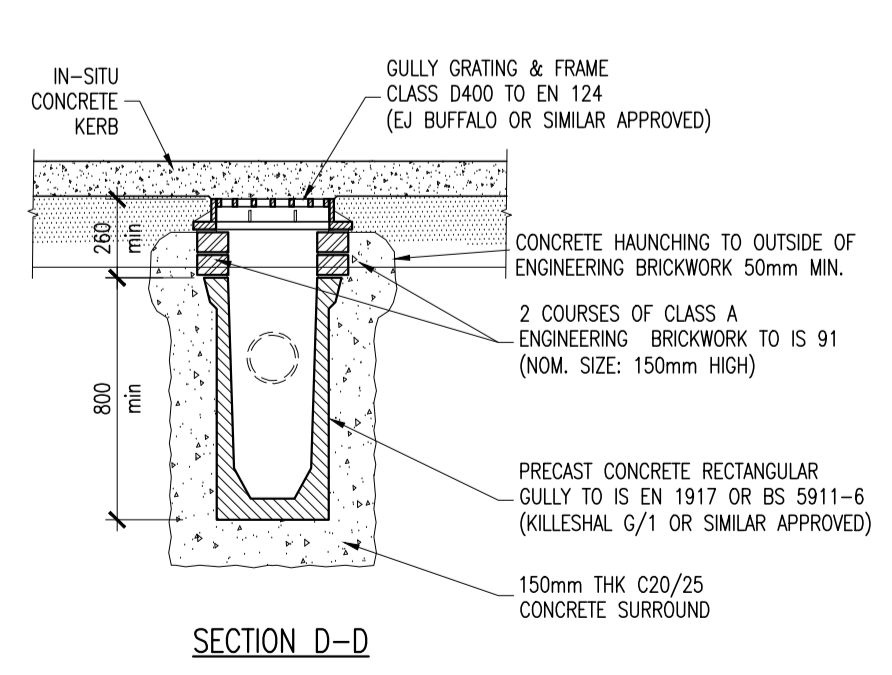
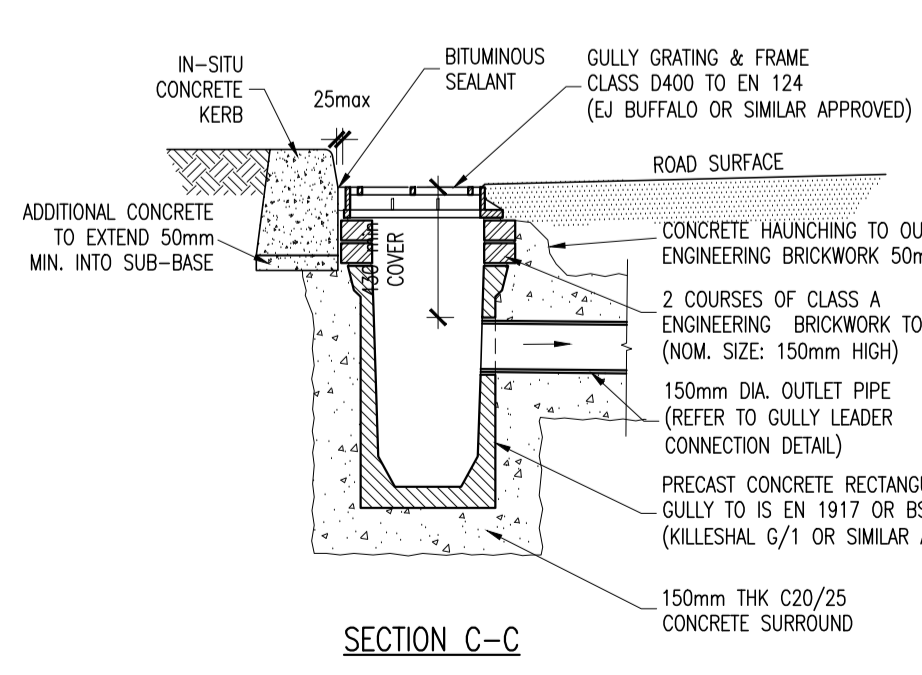
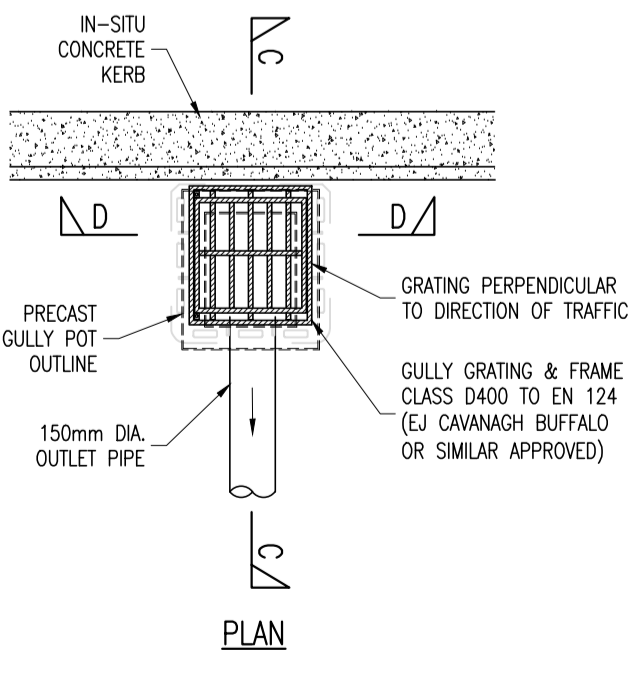
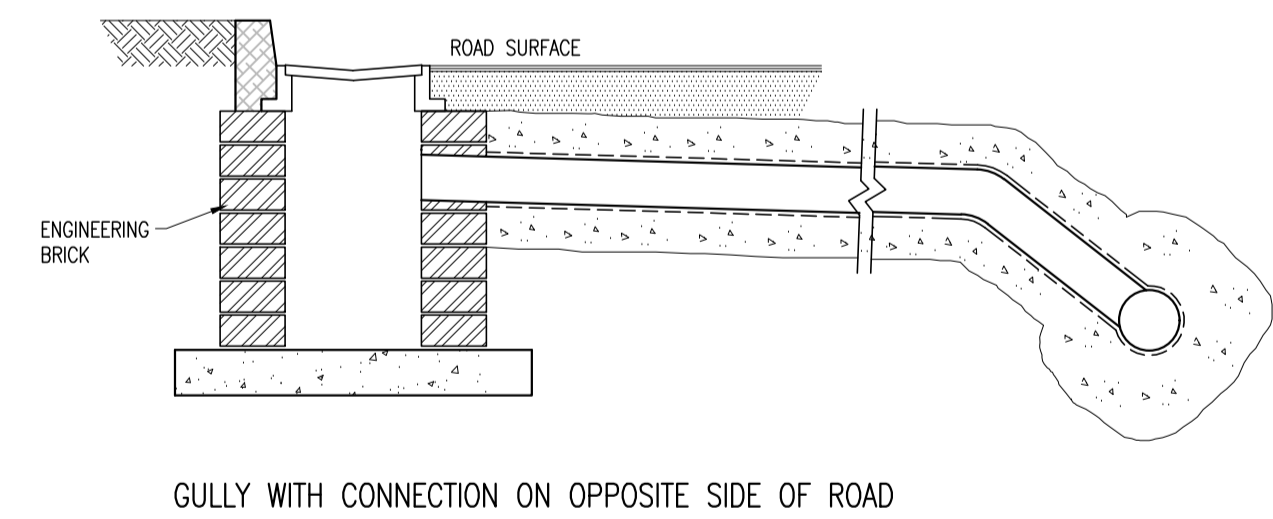
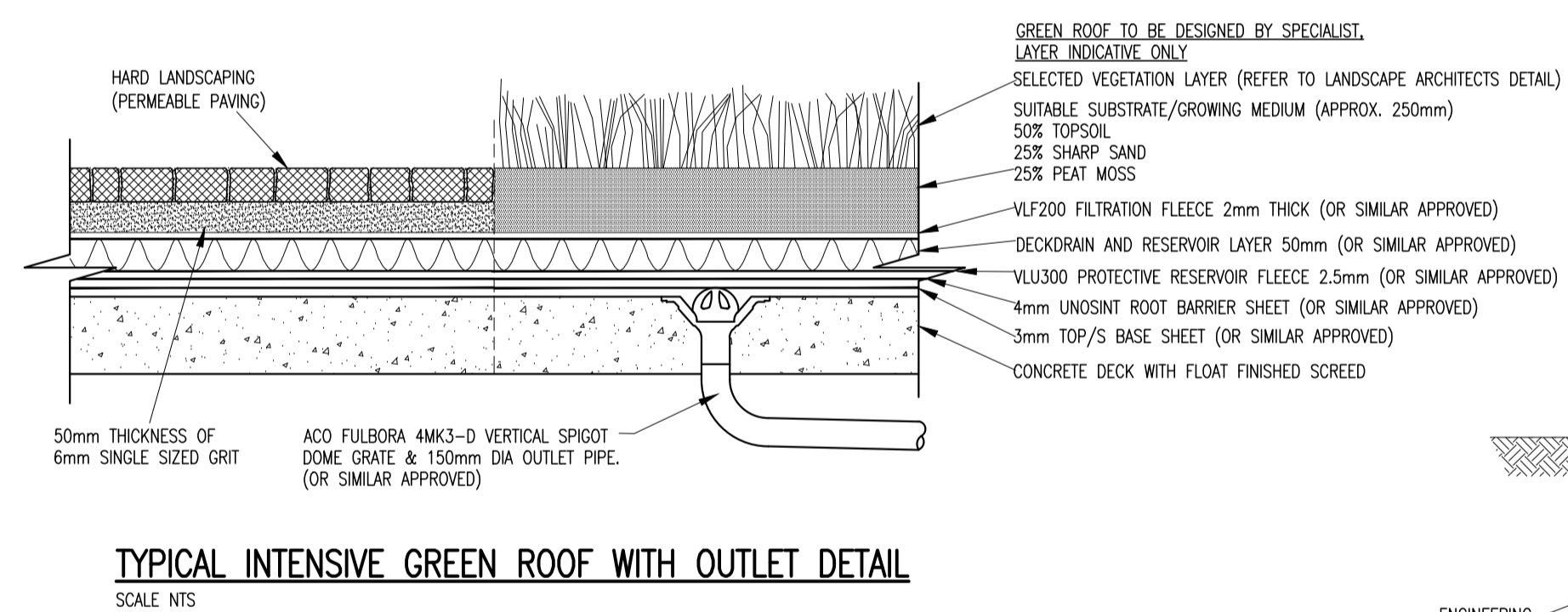
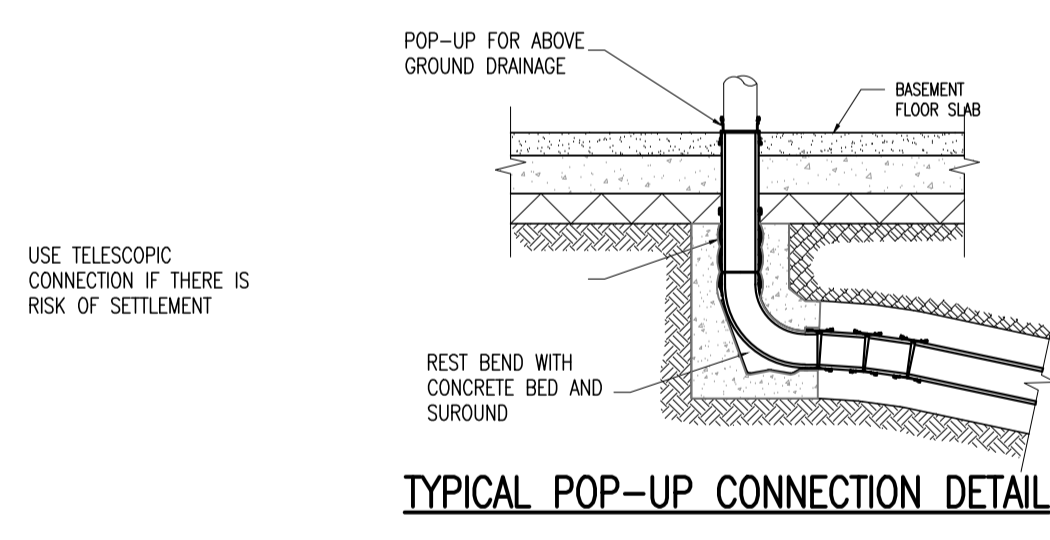
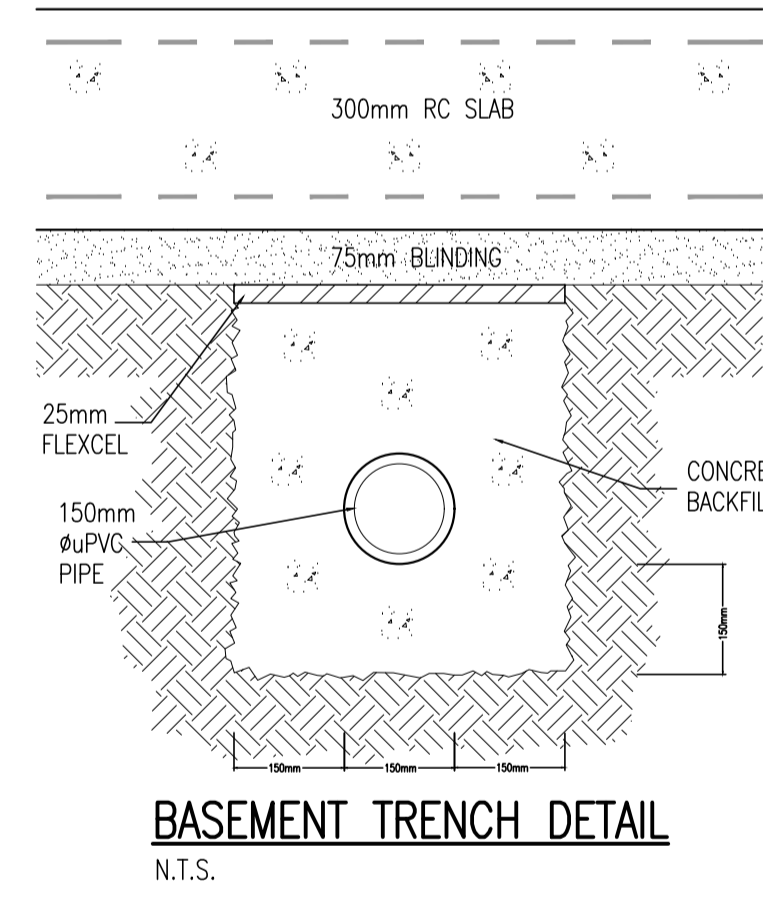
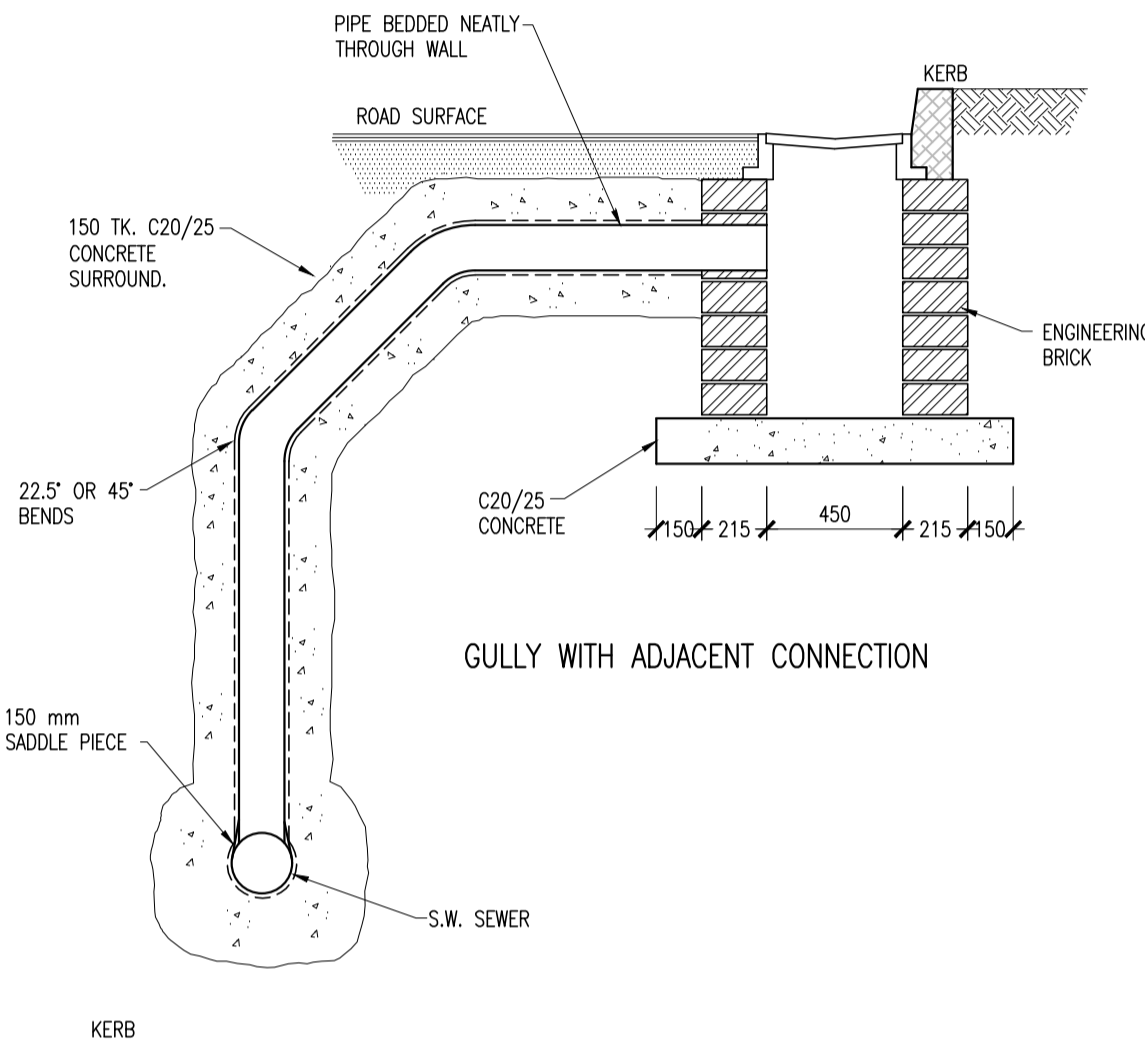
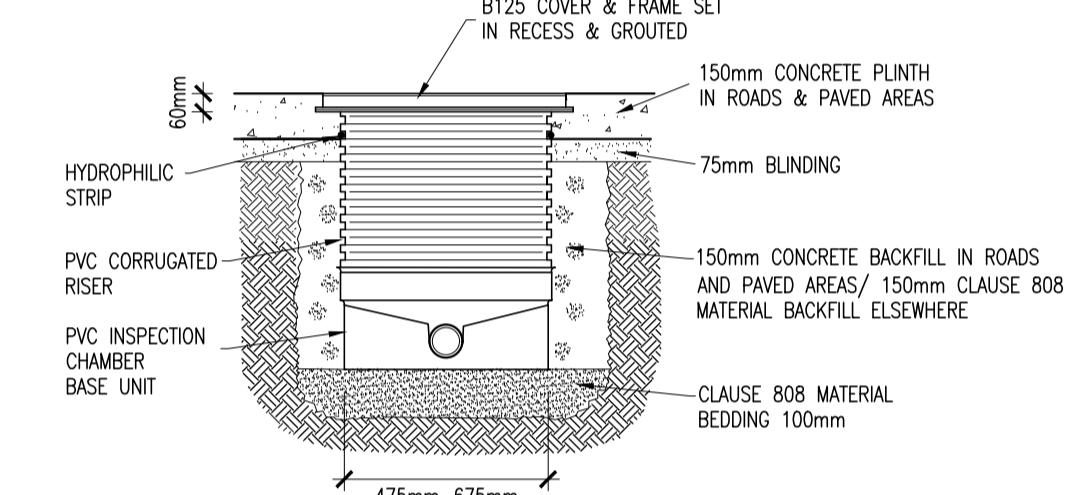
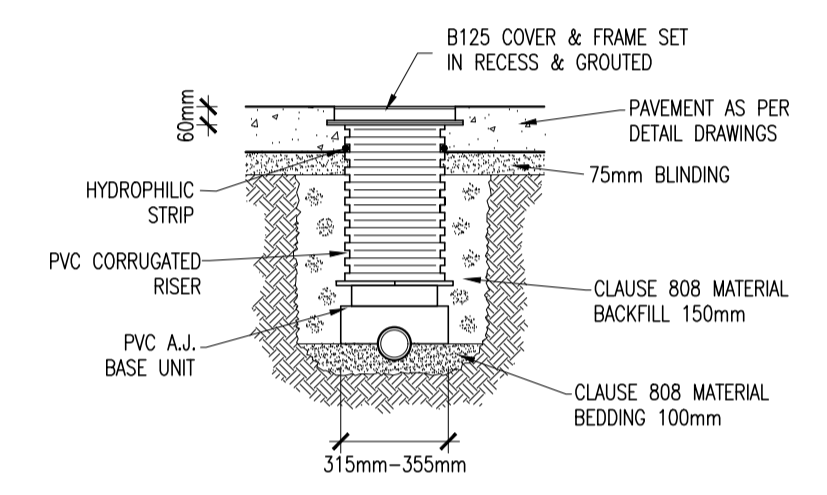
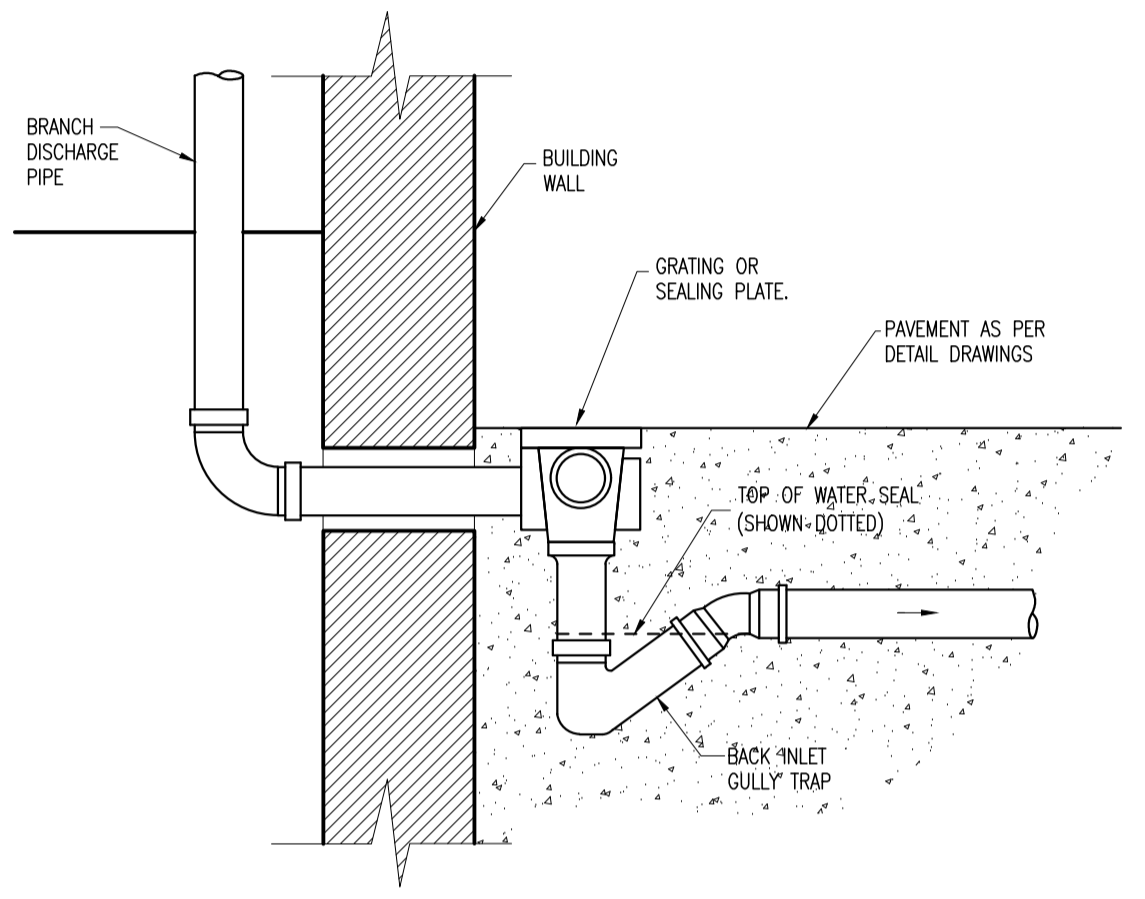

RECTANGULAR PRECAST ROAD GULLY DETAIL

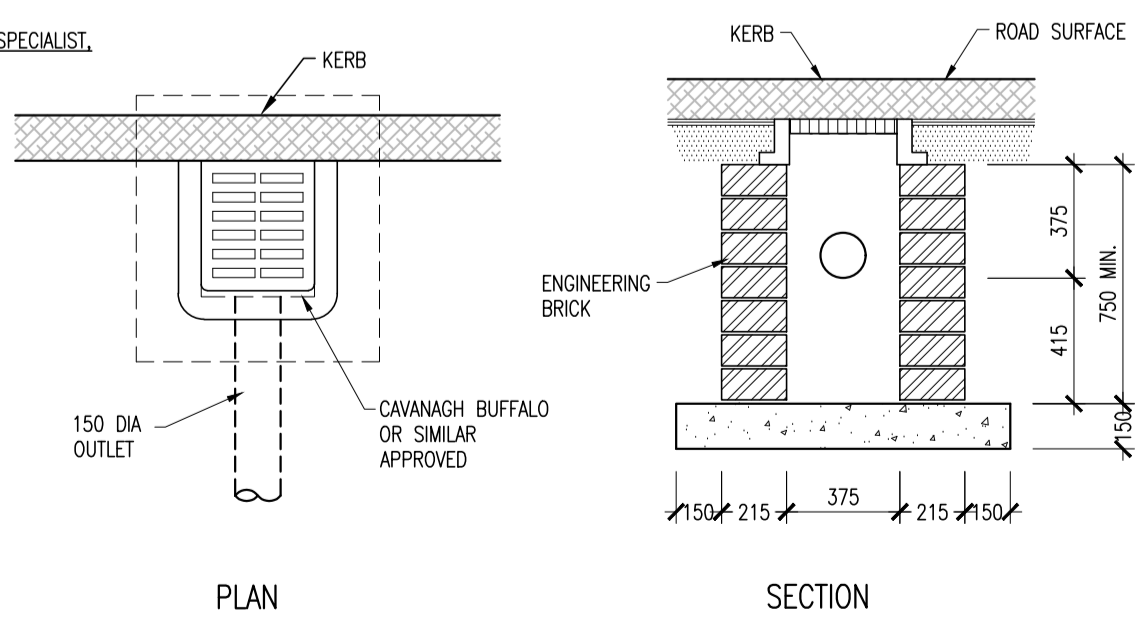
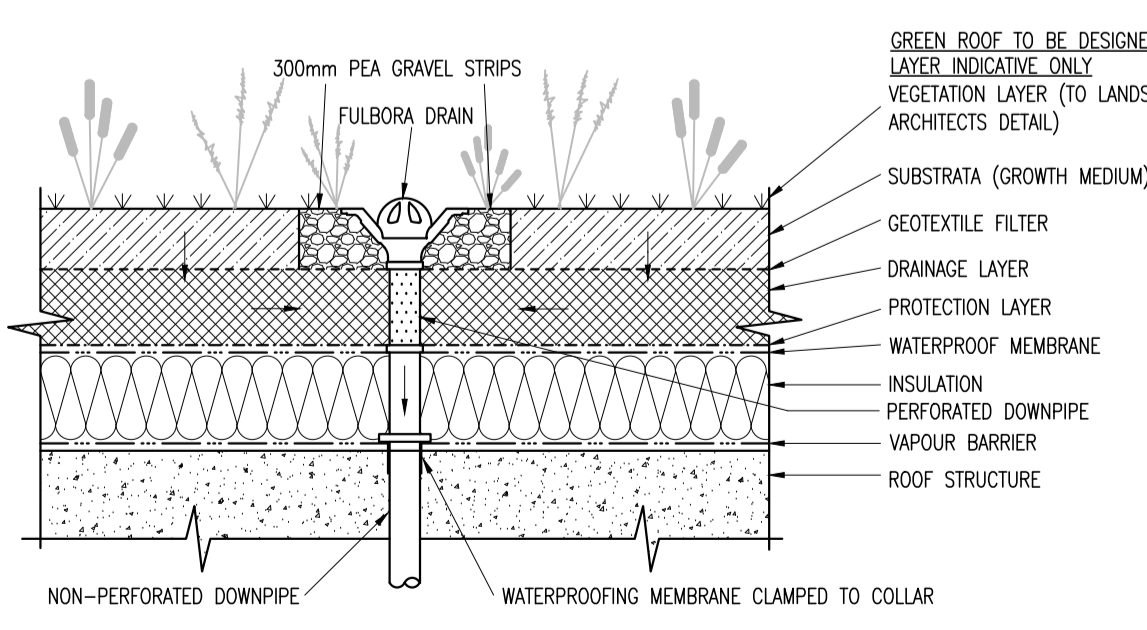

P02	15/06/21	ISSUED FOR PLANNING	DCH	LMCL
P01	28/08/20	ISSUED FOR PRE-PLANNING	DCH	LMCL
rev	date	description	by	chkd.
		A - Approved		
		B - Approved with comments		
		C - Do not use		

S2 - INFORMATION PLANNING

DBFL Consulting Engineers
Civil, Structural & Transportation Engineering
www.dbfl.ie

DUBLIN OFFICE: Ormond House, Upper Ormond Quay, Dublin 7, D07 W704
PHONE: +353 1 400 4000
CORK OFFICE: 14 South Mall, Cork, T12 CT91
WATERFORD OFFICE: Sub-B-The Juban, Warrata Gate, Canada Street, Waterford, X91 W028
PHONE: +353 51 309 500

project ref.
MIXED USE DEVELOPMENT-CHADWICKS. SWORDS ROAD, SANTRY.

drawing title
SURFACE WATER DETAILS SHEET 4 OF 6

client
DWYER NOLAN DEVELOPMENTS

designed by	author	scale	sheet size
LMCL	DCH	AS SHOWN	A1
drawing no.			revision
200060-DBFL-SW-ST-DR-C-5014			P02